



ISSM 2010 ● TOKYO

October 18 - 20, 2010
Hyatt Regency Tokyo, Shinjuku, Tokyo

ISSM2010 Networking Session

Schedule: noon-20:00, Monday, October 18

Place: Crystal Room, B1F, Hyatt Regency Tokyo

<The Objective and Target of ISSM2008 Networking Exhibition>

The ISSM Networking Session, targeting to semiconductor equipment, materials, facilities, software, and IP suppliers, provides efficient opportunities to deliver your key solutions technologies to the right targeted audience of ISSM participants.

The participation in general sessions of ISSM requires abstract review process by ISSM international program committees through call-for-paper submission. The ISSM assessment process is an objective, peer-judged process involving 60 evaluators from semiconductor companies and academia around the world. Only selected papers by ISSM's international program committees are presented either in oral session or interactive (poster) session. The Best Papers of ISSM have chances to be included in IEEE's Transaction on Semiconductor Manufacturing in the following year.

The ISSM 2010 Program Committee acknowledges the value of implementation of commercial equipment, materials, facilities, software, and intellectual properties. They supplement academic and technology-oriented concept and bring solutions in many cases. The objective of ISSM's Networking Session is to provide an excellent opportunity to the exhibiting suppliers to present their solution or concept to all participants of ISSM in interactive atmosphere.

The schedule and the venue of this session have improved offering the great opportunity to join this interactive session by appealing more audience. The venue is located just across the main conference room and the partition between the reception area and Networking Session will be removed to encourage all participants to enjoy free interaction and exchange in a relaxed atmosphere.



Booth

1. Back side Panel (W1.8m x H2.5m)
The space for display is W1.5m x H1.6m
2. Table (W1.8m x D0.6m)
3. AC Power Outlet (500W) 1
4. Spotlights 2
5. Company Name Board (in English and Japanese)

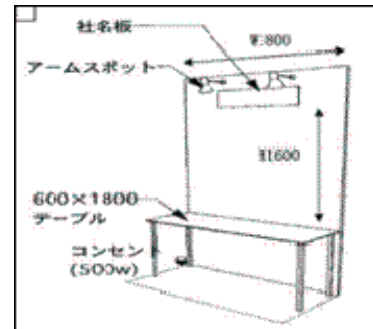

Note

1. Exhibition Fee: JPY150,000/booth unit (tax included)
2. Program committee will not set any restriction to participate exhibition due to category of business, operation and organization as far as having relevancy to semiconductor manufacturing.
3. Program committee expects material exhibition and solution proposal along with ISSM2008 theme from every exhibitor.
4. Number of Booth Minimum: 1 booth/Maximum: 2 booths
5. Closing date for application : **September 10, 2010 (Fri)** *We have extended the closing date.
6. Application : Fill in the attached form and send it to ISSM2010 Japan Office (E-mail to issm_2010@semiconportal.com or FAX to +81-3560-3565) by September 10, 2010.
7. Booth location segmented by interest area will be notified after review by ISSM2008 program committee.
8. Capacity of 30 booths.
9. Exhibit material should be written in both Japanese and English.
10. Exhibitors can bring products or promotion materials.

Cancellation Policy

Cancellation penalties will apply after the confirmation of the application is sent to the exhibitors.

- 30% of total exhibit fee for cancellation after the notification by confirmation letter till August 31, 2010.
- 50% of total exhibit fee for cancellation after the notification by confirmation letter after September 1 through September 30, 2010.
- 100% of total exhibit fee for cancellation on and after October 1, 2010.



ISSM 2010●TOKYO

October 18 - 20, 2010
Hyatt Regency Tokyo, Shinjuku, Tokyo

Important Date

September 10, 2010: Deadline of Application

September 30, 2010 : Deadline of Booth Fee Payment

9:30, October 18, 2010 : Exhibits Move-in

20:00-21:00, October 18, 2010: Exhibits Move-Out & Booth Tear Down

Shipping Instructions

<Incoming Materials>

IMPORTANT: Paid exhibit registration is required before making shipping arrangements with the Hyatt Regency Tokyo. The Hyatt Regency will not assume any responsibility for the damage or loss of merchandise sent to the Hyatt Regency Tokyo for storage.

Exhibit materials must be shipped directly to the Hyatt Regency Tokyo. Packages must arrive no earlier than October 15, 2010. Materials that arrive earlier will not be accepted.

Shipments must be addressed as follows:

Hyatt Regency Tokyo

2-7-2 Nishi-Shinjuku, Shinjuku-Ku

Tokyo 160-0023, Japan

Tel: +81 3 3348 1234

Hold For : ISSM2010 (10/18- 10/20), NETWORKING SESSION at B1F Century Room,
[Contact Name]

Arrival Date: [Contact Arrival Day & Date]

Booth Number: [Your booth number]

Exhibitors must include their return address on all box(es) shipped to the Hyatt Regency Tokyo.

<Outgoing Materials>

Guests can ship their packages out from the Networking Session venue (Century Room, B1F). All outgoing boxes must be packed, sealed, and labeled by the Exhibitor. The hotel will provide a shipping form that is used internally for proper tracking.

Inland transport/domestic

Shipment will be handled by YAMATO TRANSPORT CO., LTD. and only pay on delivery



ISSM 2010 ● TOKYO

October 18 - 20, 2010
Hyatt Regency Tokyo, Shinjuku, Tokyo

(Chakubarai) is available.

Overseas shipping

Please check with ISSM2010 Japan Office separately.

Shipping Questions

All questions related to shipping exhibitor materials should be directed to the Hyatt Regency Tokyo before the meeting.

Exhibitors are responsible for contracting for the shipment and handling of all exhibit materials. The Hyatt Regency Tokyo and Semiconductor Portal, Inc. (ISSM Japan Office) are not responsible for lost or misdirected shipments.

Others

Signs and Banners

There is to be no rigging of signs, banners, lights, sound, etc., from any ceiling in the Hyatt Regency Tokyo without their expressed prior approval. In addition, no signs are to be taped on walls, doors, columns, or windows. No nails, hooks, screws, tacks, or adhesives may be used to secure signs or other paraphernalia.

All exhibitors must observe the following rules and regulations:

- ✚ Wall, column, and permanent building outlets are not a part of booth space and are not to be used by exhibitors unless specified in writing by The Hyatt Regency Tokyo Engineering department.
- ✚ Use of open clip sockets, latex, or lamp cord wire and duplex or triplex attachment plugs in exhibits is strictly prohibited.
- ✚ All material and equipment furnished by the Hyatt Regency Tokyo staff shall remain the property of the hotel and can only be removed by hotel engineering personnel at the close of the function.
- ✚ Exhibitor is responsible for any and all damages to floor coverings and walls caused by exhibitor and/or exhibitor's employees.

Security

Each exhibitor must make provisions for safeguarding its materials, equipment, and displays at all times. Neither the Hyatt Regency Tokyo nor Semiconductor Portal, Inc will be responsible for the loss or theft of property belonging to any Exhibitor, its agents, employees, visitors, or guests. Each Exhibitor must carry full insurance for the entire duration of the show. Please include proof of your insurance with your



ISSM 2010 ● TOKYO

October 18 - 20, 2010
Hyatt Regency Tokyo, Shinjuku, Tokyo

registration. Exhibitors assume all responsibility for compliance with local, city, county, state, and federal ordinances and regulations covering fire, safety, and health. Only fireproof materials should be used in displays and Exhibitors should take necessary fire precautions.

Exhibitor Responsibilities

In the event that any damage occurs to the Hyatt Regency Tokyo furniture, fixtures, building, or equipment caused by installation, presence, and/or removal of exhibit materials, the Exhibitor shall reimburse the Hyatt Regency Tokyo for the cost of such repair, or replacement as may be necessary.

Disclaimers

By registering as an Exhibitor, the Exhibitor indemnifies and agrees to hold harmless the Hyatt Regency Tokyo and Semiconductor Portal, Inc. (ISSM Japan Office) its officers, directors, employees and agents, from and against any actions, losses, costs, damages, and expenses (including attorney fees) arising from damages to property or bodily injury to the Exhibitor, his agents representatives and employees by reason of the Exhibitor's occupancy or use of the Exhibitor's facilities.

Hyatt Regency Tokyo and Semiconductor Portal, Inc. (ISSM Japan Office) are not responsible for any lost, stolen, damaged or misdirected equipment, personal items or business related property brought onto the premises by an Exhibitor, guest, group contractor, etc. This includes items that are in the meeting rooms outside of the event hours.

Contact

ISSM Japan Office at Semiconductor Portal, Inc.

E-mail: issm_2010@semiconportal.com

Phone: +81-3-3560-3565

FAX: +81-3-3560-3566



Map & Directions

Hyatt Regency Tokyo

<http://tokyo.regency.hyatt.com/>
 2-7-2 Nishi-Shinjuku, Shinjuku-Ku
 Tokyo 160-0023, Japan
 Tel: +81 3 3348 1234
 Fax: +81 3 3344 5575



Access to Hyatt Regency Tokyo

From Narita International Airport - Airport Limousine Bus for Narita International Airport (2 hours) One-way adult fare - JPY 3000

Airport Limousine Bus for Haneda Domestic Airport (1 hour 10 minutes) One-way adult fare - JPY 1200 Visit <http://www.limousinebus.co.jp> for further information on timetables.

Narita Express Train Service from Narita Station to Shinjuku Station (1 hour 20 minutes) One-way fare - JPY 3110 (low season), JPY 3310 (high season)

* An additional taxi is required from Shinjuku Station to the hotel or it takes nine minutes to walk.

Tentative ISSM2010 Program Schedule * the program schedule is subject to changed

	Monday, October 18			Tuesday, October 19		Wednesday, October 19	
	Room 1	Room 2	Room 3	Room 1	Room 2	Room 1	Room 2
	Registration			Registration		Registration	
AM	9:40 Opening Remarks			9:40 Keynote Speaker		9:40 Keynote Speaker	
	10:00 Keynote Speaker			10:40 Keynote Speaker		10:40 Keynote Speaker	
	11:00 Keynote Speaker			11:40 Lunch		11:40 Lunch	
	12:00 Lunch			13:00 PO FD		13:00 FM PC	
PM	13:20 PO MC			13:20 PO FD		13:20 UC PC	
	13:40 PO MC			13:40 PO MS		13:40 UC PC	
	14:00 PO MC			14:00 PO MS		Author's interview & Break	
	14:20 PO MC			14:20 Author's interview & Break		14:20 YE PC	
	14:40 Author's interview & Break			14:40 PE PC		14:40 YE PC	
	15:00 PO MC			15:00 PE PC		15:00 YE PC	
	15:20 PO MC			15:20 PE PC		15:20 Author's interview & Break	
	15:40 PO MC			15:40 Author's interview & Break		15:40 YE PC	
	16:00 PO ES			16:00 3-minutes talk/Interactive 3-minutes talk/Interactive		16:00 DM PC	
	16:20 Author's interview & Break			16:20 3-minutes talk/Interactive 3-minutes talk/Interactive		16:20 DM PC	
Ev	16:40			17:00		16:40 Author's interview & Break	
	17:20 Reception			17:00 Poster Session&Cocktail		17:00	
	19:00			18:00			